

HI-SCAN™ 6040-2is

DUAL-VIEW X-RAY INSPECTION FOR HAND LUGGAGE



Feature Highlights

- **Compact footprint and weighs less than 850 kg (1873 lbs)**
- **Guaranteed steel penetration of 35 mm (1.38")**
- **Flexible design for easier installation through door widths of 900 mm (35.5")**
- **Dual-view technology**
- **Operator friendly interface**
- **Available in standard and high resolution**

HI-SCAN 6040-2is is an advanced dual view X-ray inspection system for automatic explosive detection. It offers high throughput at security checkpoints, where bags and personal belongings are screened, utilising proven Heimann X-ray technology to detect dangerous and illegal objects, highlighted in excellent, high quality dual-view images.

With its modern, contemporary design the HI-SCAN 6040-2is provides increased flexibility, with its compact footprint and lower weight, less than 850 kg (1873 lbs). It can be used in areas that are restricted in space and will fit through doorways of 900 mm (35.5") for installation.

It offers further flexibility with different monitor options and an integrated lockable keyboard. Monitors can be placed on top of the X-ray unit or on a wheeled stand, to provide remote operation away from the machine.

HI-SCAN 6040-2is comes with a guaranteed steel penetration of 35 mm (1.38") and an operator friendly interface which makes it easy for the user to identify illegal objects and explosives that pose a threat to society.

Available in standard and also in high resolution to include EU certified liquid explosive detection (LEDS), providing the Standard 2 Type C capability*.

The HI-SCAN 6040-2is is suitable for airports, government buildings, hotels and other critical infrastructure applications where reliable security solutions are required.

*LEDS available in 2014 for high resolution only

Technical Data HI-SCAN 6040-2is

General Specifications

Tunnel dimensions	620 (W) x 420 (H) [mm] • 24.4" (W) x 16.5" (H)
Max. object size	615 (W) x 410 (H) [mm] • 24.2" (W) x 16.1" (H)
Conveyor height ¹⁾	approx. 800 mm [21.5"]
Conveyor speed with 50 Hz / 60 Hz mains frequency	standard: 0.2/0.24 [m/s]
Max. conveyor load even distributed over the whole conveyor	160 kg [352 lbs]
Resolution (wire detectability) ²⁾	standard resolution (SR): standard: 39 AWG • typical: 40 AWG high resolution (HR): standard: 40 AWG • typical: 41 AWG standard: 35 mm • typical: 37 mm
Penetration (steel) ²⁾	4.6 µSv
X-ray dose (typical)	< 1 µSv/h
External dose	guaranteed up to ISO 1600 (33 DIN) with a maximum of 5 inspections
Film safety	100 %, no warm-up procedure required
Operating cycle	

X-ray Generator

X-ray generators	2
Anode voltage • cooling	160 kV cp • hermetically sealed oil bath
Beam direction	horizontal and vertical

Image Generating System

X-ray converter	dual-view detector system with large-scale integrated, monolithic amplifier
Grey levels stored	4096
Image presentation	B/W, color, HI-MAT ^{Plus}
Digital video memory	1280 x 1024 / 24 bit
Image evaluation functions	VARI-MAT, O ² , OS, HIGH, LOW, NEG stepless, electronic Zoom: enlargement: up to 16 times
Monitor	Flat Panel LCD Monitor

Additional Features

Functions	fading-in of date/time, luggage counter, user id-number, luggage marking system (acoustic), display of operating mode, REVIEW-feature (to recall previously visible image areas), zoom overview, free programmable keys, USB 2.0 interface, stepless zoom
Options	HI-TIP, HI-SPOT, SEN, XPlore, IMS (image management system), Xport, Media Bay for RIDA (250 GB)

Installation Data

X-ray leakage	meets all applicable laws and regulations with respect to X-ray emitting devices
CE labelling/directives	in compliance with directives 2004/108/EC, 2006/42/EC, 2006/95/EC developed in accordance with directives IEC, UN, UL, CSA
Sound pressure	< 65 dB(A)
Operating-/storage temperature	0° - 40°C / -20°C - +60°C
Humidity	10% - 90% (not condensing)
Power supply	standard: 100, 120, 200, 230, 240 VAC +10% / -20% • 50 Hz - 60 Hz ± 3 Hz
Power consumption	max. 1.2 kVA
Protection class system/keyboard	IP 20 / IP 43
Dimensions • weight ⁴⁾	2340 (L) x 1314 (W) x 1372 (H) [mm] • approx. 820 kg
Mechanical construction	steel construction with steel panels, mounted on roller castors standard color(s): silver matt / B11-W1 (blue)

¹⁾ approx. values (adjustable)

²⁾ proprietary quality management test piece: steel step wedge, CU wires, belt speed 0.2 m/s

³⁾

⁴⁾ without control desk, keyboard, monitor(s) etc.

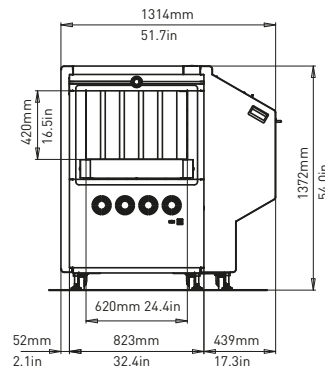
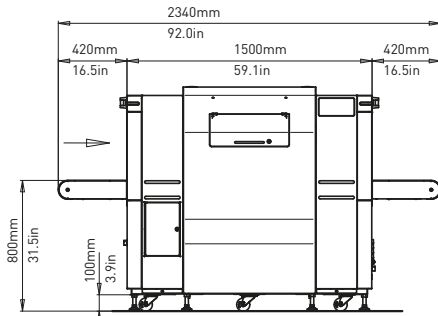

For product information, sales or service, please go to www.smithsdetection.com/locations

Smiths Heimann GmbH, Im Herzen 4, 65205 Wiesbaden, Germany
Modifications reserved. 95594337 09/08/2013 © Smiths Detection Group Ltd. - In some cases, the figures contain options
HI-SCAN is a trademark of Smiths Detection Group Ltd.